



MACRO

EXTRUSÃO DE ALUMÍNIO

CATÁLOGO DE PRODUTOS

LINHA
TUBOS

versão



TUBO REDONDO

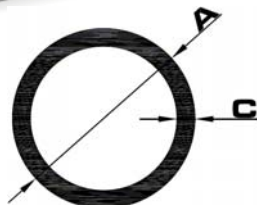

Peso por metro	POLEGADAS		MILÍMETROS	
	A	B	A	B
0,072	3/8	---	9,53	1,00
0,107	3/8	1/16	9,53	1,59
0,099	1/2	---	12,70	1,00
0,150	1/2	1/16	12,70	1,59
0,113	9/16	---	14,29	1,00
0,171	9/16	1/16	14,29	1,59
0,126	5/8	---	15,88	1,00
0,192	5/8	1/16	15,88	1,59
0,153	3/4	---	19,05	1,00
0,235	3/4	1/16	19,05	1,59
0,180	7/8	---	22,23	1,00
0,278	7/8	1/16	22,23	1,59
0,207	1	---	25,40	1,00
0,321	1	1/16	25,40	1,59
0,234	1.1/8	---	28,58	1,00
0,363	1.1/8	1/16	28,58	1,59
0,261	1.1/4	---	31,75	1,00
0,406	1.1/4	1/16	31,75	1,59
0,315	1.1/2	---	38,10	1,00
0,492	1.1/2	1/16	38,10	1,59
0,368	1.3/4	---	44,45	1,00
0,577	1.3/4	1/16	44,45	1,59
0,422	2	---	50,80	1,00
0,662	2	1/16	50,80	1,59
0,476	2.1/4	---	57,15	1,00
0,748	2.1/4	1/16	57,15	1,59
0,530	2.1/2	---	63,50	1,00
0,833	2.1/2	1/16	63,50	1,59

FAZEMOS QUALQUER MEDIDA DE TUBO REDONDO DESDE QUE POSSUA DIÂMETRO EXTERNO DE 3/8" a 2.1/2" E ESPESSURA MÍNIMA DE 1,0mm, INCLUINDO A LINHA SCHEDULE.



TUBO QUADRADO

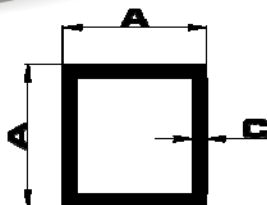

Peso por metro	POLEGADAS		MILÍMETROS	
	A	B	A	B
0,159	1/2	---	12,70	1,30
0,191	5/8	---	15,88	1,20
0,246	5/8	1/16	15,88	1,59
0,196	3/4	---	19,05	1,00
0,301	3/4	1/16	19,05	1,59
0,546	3/4	1/8	19,05	3,18
0,398	---	1/16	24,70	1,59
0,315	1	---	25,40	1,20
0,410	1	1/16	25,40	1,59
0,507	1	---	25,40	2,00
0,765	1	1/8	25,40	3,18
0,489	---	1/16	30,00	1,59
0,519	1.1/4	1/16	31,75	1,59
0,645	1.1/4	---	31,75	2,00
0,983	1.1/4	1/8	31,75	3,18
0,402	1.1/2	---	38,10	1,00
0,628	1.1/2	1/16	38,10	1,59
0,783	1.1/2	---	38,10	2,00
0,661	---	1/16	40,00	1,59
0,824	---	---	40,00	2,00
1,267	---	1/8	40,00	3,18
0,540	2	---	50,80	1,00
0,848	2	1/16	50,80	1,59
1,159	2	---	50,80	2,20
1,642	2	1/8	50,80	3,18
1,642	*2	*1/8	50,80	3,18
2,428	*---	*---	60,00	4,00

* TUBOS DE CANTOS ARREDONDADOS.



TUBO RETANGULAR

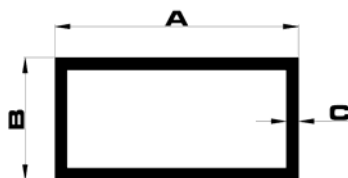

Peso por metro	POLEGADAS			MILÍMETROS		
	A	B	C	A	B	C
0,179	*---	*---	*---	20,00	10,00	1,20
0,176	---	---	---	20,00	14,50	1,10
0,206	*---	*---	*---	25,00	15,00	1,00
0,239	*1	*1/2	*---	25,40	12,70	1,25
0,699	---	---	---	27,50	18,00	3,00
0,357	*---	*---	*---	28,20	18,65	1,50
0,244	*---	*---	*---	30,00	10,00	1,20
0,403	---	---	1/16	30,00	20,00	1,59
0,409	*1.1/2	*1	*---	38,10	25,40	1,25
0,570	---	---	---	38,30	18,30	2,00
0,661	---	---	---	40,00	25,00	2,00
0,715	---	---	---	40,00	30,00	2,00
0,453	---	---	---	48,00	24,00	1,20
0,425	---	---	---	50,00	13,00	1,30
0,402	2	1	---	50,80	25,40	1,00
0,628	2	1	1/16	50,80	25,40	1,59
1,202	2	1	1/8	50,80	25,40	3,18
1,995	---	---	---	60,00	40,00	4,00

* TUBOS DE CANTOS ARREDONDADOS.



**TUBOS ESPECIAIS
OBILONGO**

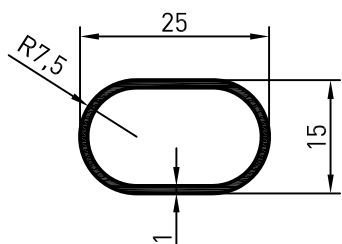

M-120

0,173 kg/m

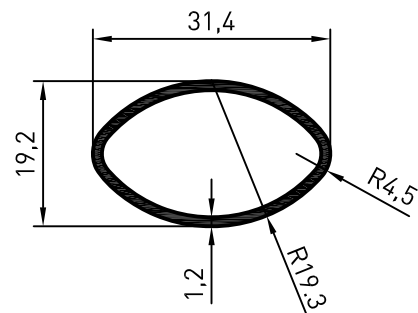

M-163

0,245 kg/m

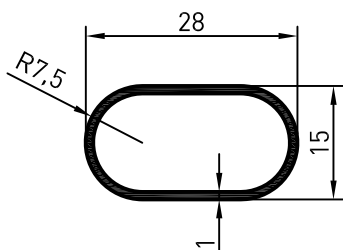

M-422

0,190 kg/m

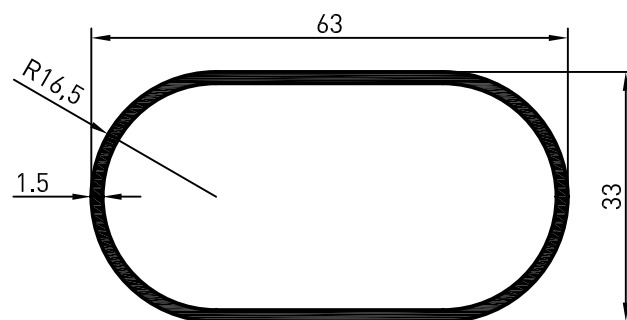

M-492

0,646 kg/m

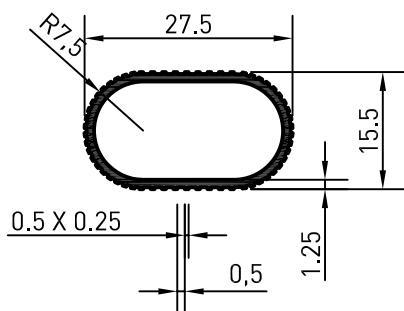

M-855

0,204 kg/m

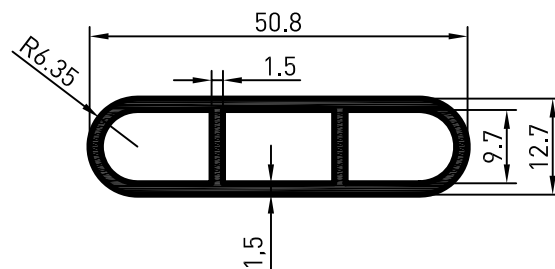

M-901

0,536 kg/m



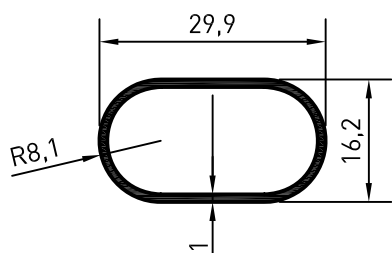

M-1114

0,203 kg/m

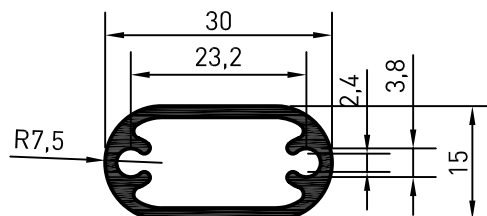

M-1280

0,373 kg/m

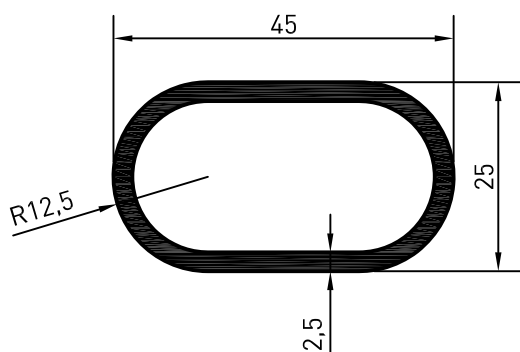

M-1383

0,750 kg/m

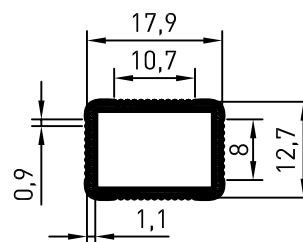

M-767

0,132 kg/m

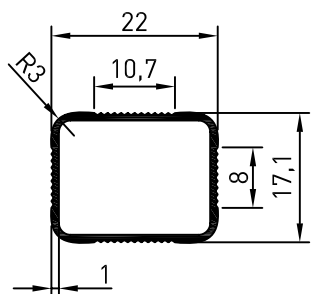

M-768

0,710 kg/m

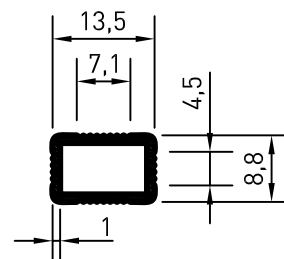

M-907

0,097 kg/m



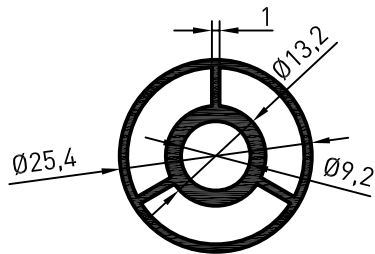

M-800

0,439 kg/m

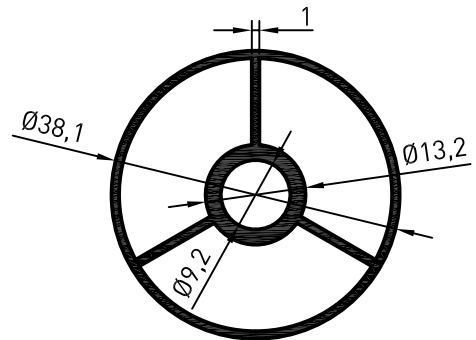

M-831

0,702 kg/m

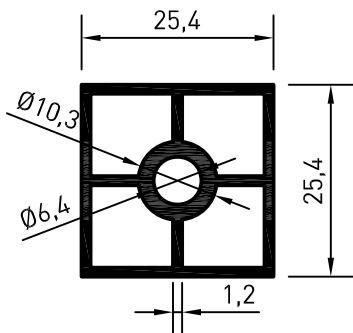

M-856

0,569 kg/m

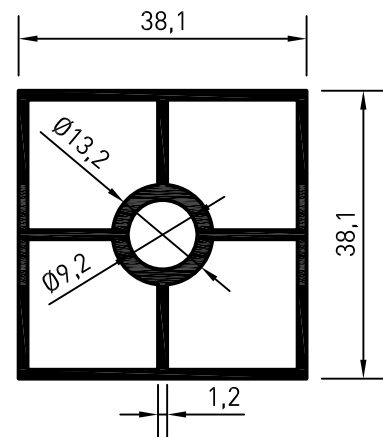

M-857

0,817 kg/m

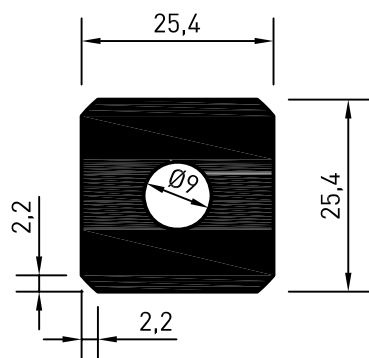

M-1105

1,552 kg/m

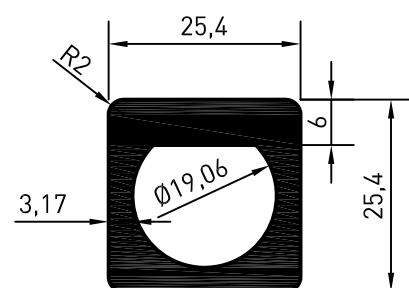

M-1211

1,037 kg/m



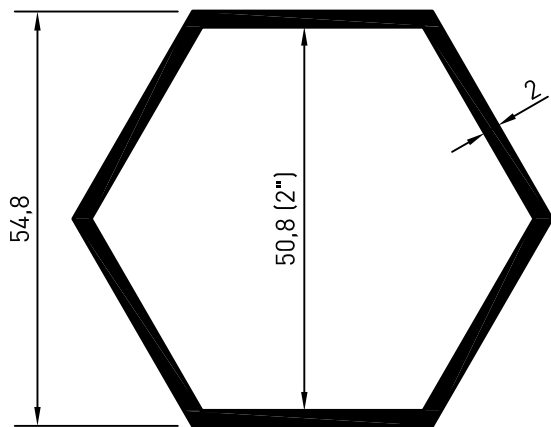

M-969

0,992 kg/m

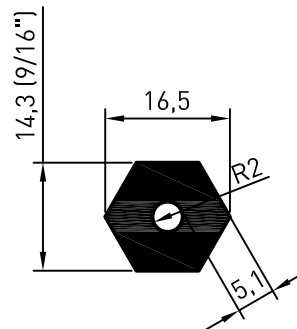

M-1121

0,445 kg/m

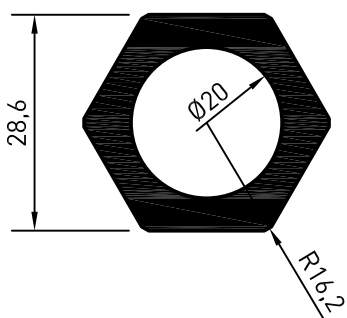

M-1126

1,062 kg/m

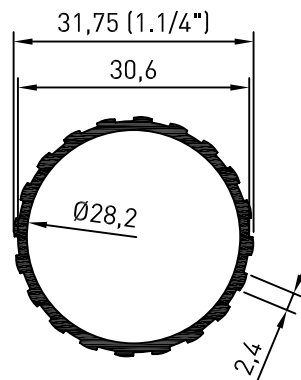

M-560

0,369 kg/m

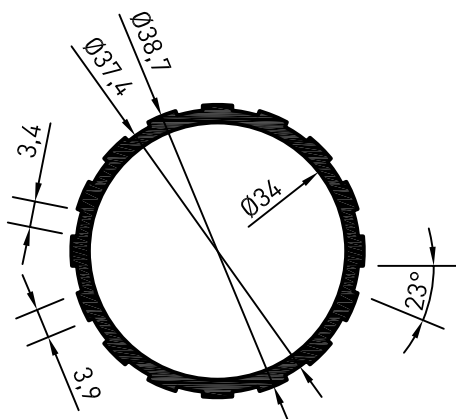

M-991

0,627 kg/m

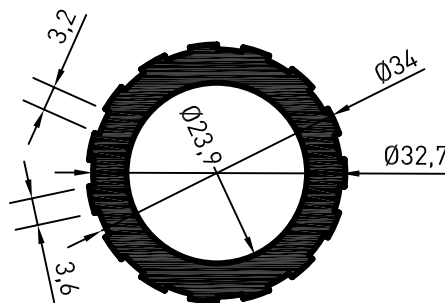

M-992

1,156 kg/m



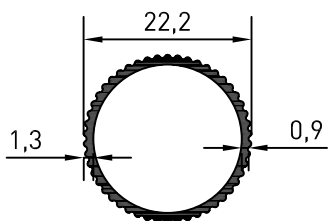

M-177

0,195 kg/m

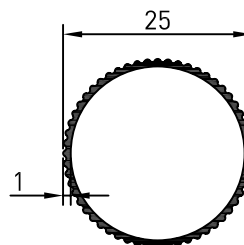

M-66

0,180 kg/m

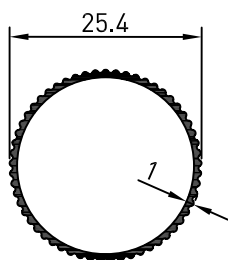

M-28

0,185 kg/m

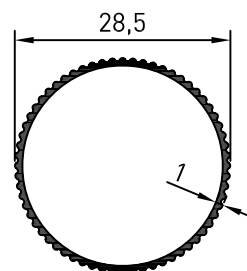

M-12

0,220 kg/m

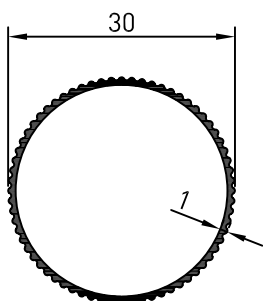

M-67

0,245 kg/m

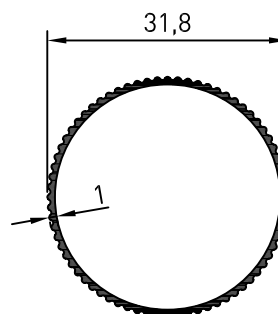



M-116

0,250 kg/m



 Estrada do Una, 305 – Bairro do Una
Itaquaquecetuba/SP CEP: 08599-650

 (11) 4647-8080/4644-1931

 contato@macroaluminio.com.br
vendas@macroaluminio.com.br

 www.macroaluminio.com.br

